

manual

linea mini

La Marzocco's linea mini is a handmade, professional-grade espresso machine for the home, reflecting the classic, iconic design in a miniature version. The linea mini, with its stainless steel group for coffee, and a boiler for steam and hot water, is prepared to brew quality shots with freshly ground coffee, coffee capsules or pods as well as tea or other hot beverages.



la marzocco

handmade in florence

linea mini

Operating Manual V1.1 - 04/2015



la marzocco

handmade in florence

Chapters

1. Important Safeguards	page 3
2. General Information	page 5
3. Machine Description	page 8
4. Installation	page 9
5. Operation	page 13
6. Key Features	page 15
7. Preventative Maintenance and Cleaning	page 16
8. Installation Guide	page 18

La Marzocco S.r.l.

Via La Torre 14/H
Località La Torre
50038 Scarperia e San Piero
(Florence) - ITALY

www.lamarzocco.com
info@lamarzocco.com

T: +39 055 849 191
F: +39 055 849 1990

FN

certifications available:



1. Important Safeguards

WARNING
SAVE THESE INSTRUCTIONS

IMPORTANT SAFEGUARDS

When using electrical appliances, basic safety precautions should always be followed, including the following:

1. Read all instructions.
2. Do not touch hot surfaces. Use handles or knobs.
3. To protect against fire, electric shock and injury to persons do not immerse cord, plugs, or electrical parts in water or other liquid.
4. Close supervision is necessary when any appliance is used by or near children.
5. Unplug from outlet when not in use and before cleaning. Allow to cool before putting on or taking off parts, and before cleaning the appliance.
6. Do not operate any appliance with a damaged cord or plug or after the appliance malfunctions, or has been damaged in any manner. Return appliance to the nearest authorized service facility for examination, repair or adjustment.
7. The use of accessory attachments not recommended by the appliance manufacturer may result in fire, electric shock or injury to persons.
8. Do not use outdoors.
9. Do not let cord hang over edge of table or counter, or touch hot surfaces.
10. Do not place on or near a hot gas or electric burner, or in a heated oven.
11. Always attach plug to appliance first, then plug cord into the wall outlet. To disconnect, turn any control

WARNING
SAVE THESE INSTRUCTIONS

IMPORTANT SAFEGUARDS

- to “off,” then remove plug from wall outlet.
12. Do not use appliance for other than intended use.
13. Save these instructions.
14. Use, cleaning and maintenance of this coffee machine are realized by people (including children more than 8 years of age) with reduced physical, sensory or mental capabilities, or lack of experience and knowledge, as long as they have been given supervision by a person responsible for their safety and if they understand dangers.
15. The service area is restricted to persons having knowledge and practical experience of the appliance, in particular as far as safety and hygiene are concerned.
- Children should be supervised to ensure that they do not play with the appliance.
- Keep the appliance and its cord out of the reach of children less than 8 years of age.

2. General Information

WARNING

The manufacturer declines any responsibility for any event leading to liability suits whenever grounding has not been completed according to current local, national, and international regulations and electrical codes, or other electrical parts have been connected improperly.

WARNING

This appliance is not intended for use by persons (including children) with reduced physical, sensory or mental capabilities, or lack of experience and knowledge, unless they have been given supervision or instruction concerning use of the appliance by a person responsible for their safety.

WARNING

Hazardous voltage disconnect from power supply before servicing.

WARNING

The machine must be installed so that qualified technical personnel can easily access it for maintenance.

WARNING

In order to prevent cracks or leakage: do not store or install the coffee machine in places where temperature may cause boiler or hydraulic system water freezing.

Espresso coffee machine essentially made up of a brewing group of hot water for espresso coffee and a steam boiler that is able to supply steam and hot water for infusions.

This appliance is intended to be used for household and similar applications such as:

- staff kitchen areas in shops, offices and other working environments;
- farm houses;
- by clients in hotels, motels and other residential-type environments;
- bed & breakfast-type environments.

About this manual

This operating guide is an integral and essential part of the product and must be supplied to users. Users are asked to read the enclosed warnings and cautions carefully, as they provide valuable information concerning safety during installation, operation, and maintenance. This manual must be kept in a safe place and be available for consultation to new and experienced users alike.

Remove machine from packaging

1) Ensure product's integrity by inspecting the packaging, making sure it presents no

signs of damage which might have affected the enclosed machine.

2) Check the machine's integrity after having carefully removed the packaging. Packaging (boxes, plastic bags, foam parts and whatever else) must not be left within easy reach of children, due to the potential danger it represents, nor be discarded in the environment.

Safety instructions

1) Check to see that data on the rating plate corresponds to those of the main electrical supply to which the machine will be attached.

This equipment must be installed to comply with applicable federal, state or local plumbing codes.

2) The installation must be performed according to local electrical and plumbing codes and regulations. The installation also must comply to the manufacturer's instructions, and must be performed by qualified and authorized personnel.

3) Incorrect installation may cause injury/damages to people, animals or objects, for which the manufacturer shall not be held responsible.

4) Safe electrical operation of this device will be achieved only when the connection to the power outlet has been completed correctly and in observance of all local, national, and international electrical codes and safety regulations, and particularly by grounding the unit. Make sure grounding has been done properly as it represents a fundamental safety requirement. Ensure qualified personnel check such connection.

5) Furthermore, you must ensure that the capacity of the available electrical system is suitable for the maximum power consumption indicated on the espresso machine.

6) We do not recommend using adapters, multiple plugs and/or extension cords. If you cannot avoid using them, make sure that they are exclusively of the kind which conforms to local, national, and international electrical codes and safety regulations, being careful not to exceed the power and current ratings indicated on such adapters and extension cords.

7) This device must be used exclusively for the functions it has been designed and built for. Any other application is inappropriate and dangerous.

The manufacturer shall not be held

responsible for any damages caused by improper and/or irrational use.

8) Using any electrical device requires that certain fundamental rules be observed. In particular:

- do not touch the device with wet or moist hands and feet
- do not use the device while not wearing shoes
- do not use extension cords in bath or shower rooms
- do not unplug the device from the power outlet by pulling on the power supply cable
- do not expose the device to atmospheric agents
- do not allow children or untrained people to use this device

9) Before performing any maintenance and/or cleaning operations (other than back-flushing the group), turn the main switch to the "O" position, and disconnect the machine from the electrical network by unplugging the cord or by switching off the relative circuit breaker. For any cleaning operation, follow exclusively the instructions contained in this manual.

10) If the machine is operating in a faulty manner or stops working, disconnect it from the electrical network (as described in the preceding point). Do not attempt to repair it. Contact a qualified and authorized professional to perform any repair. Any repair must be performed exclusively by the manufacturer or by an authorized centre using only original parts. Non compliance with the above could compromise the safe operation of the machine.

11) In order to avoid dangerous overheating problems, it is recommended that the power supply cable be unfurled completely.

12) Do not obstruct air intake and exhaust grilles and, in particular, do not cover the cup warmer tray with cloths or other items.

13) The machine's power supply cable must not be replaced by users. In case the power supply cable becomes damaged, shut off the machine and disconnect the machine from the electrical network by unplugging the power cord or switching off the relative circuit breaker and close off the water supply; to replace the power supply cord, contact qualified professionals exclusively.

14) These instructions are also available in an alternative format on a website.

3. Machine Description

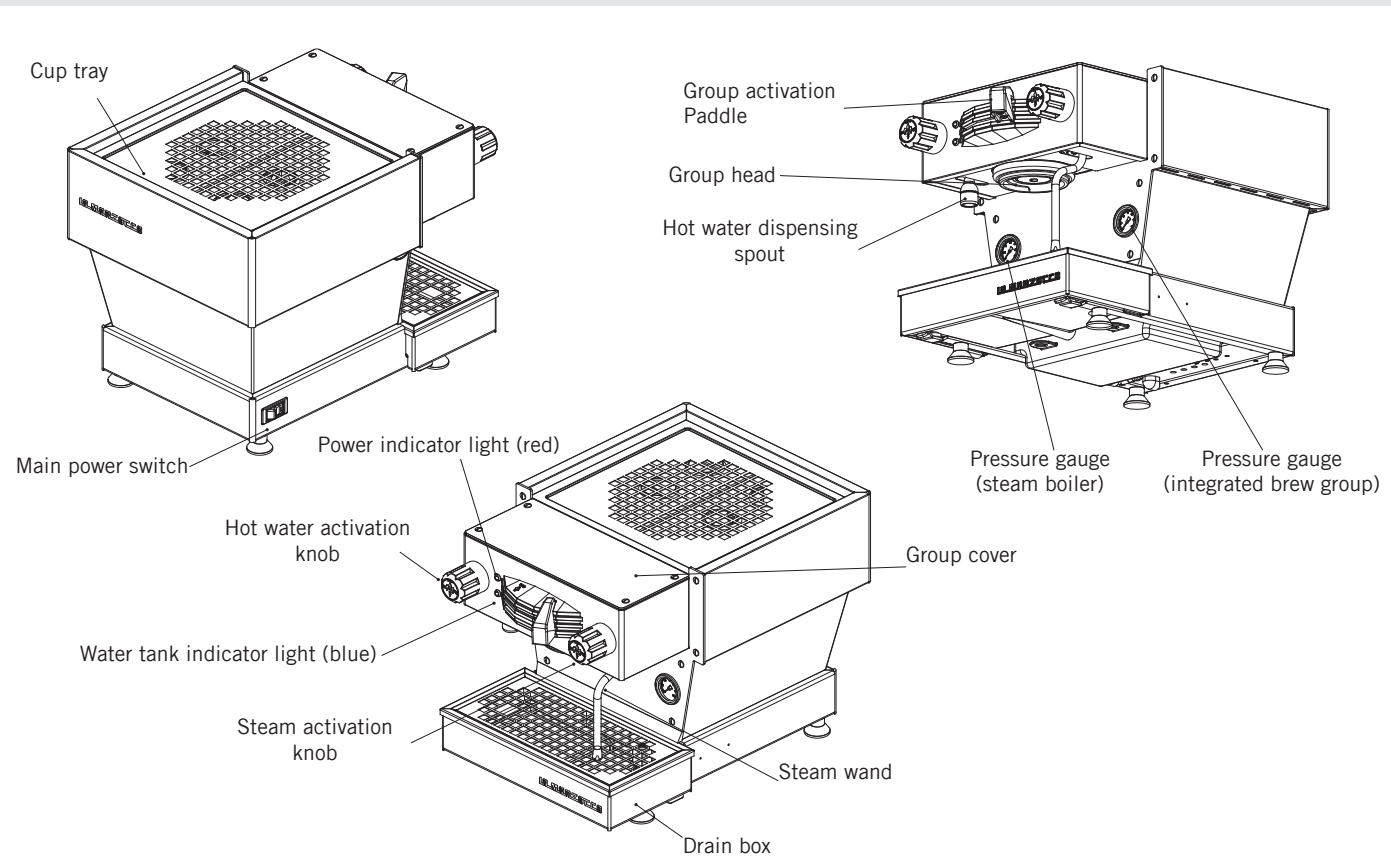

Figure 1 - Machine Description

4. Installation

WARNING
The coffee machine must be placed in a horizontal position on a counter higher than 90 cm from the ground.

WARNING
The expansion valve can discharge water as hot as 200°F / 93°C. Adequate protection for handling this component is needed before attempting to adjust.

WARNING
This machine is not suitable for outdoor use.

Note:

- Minimum room temperature: **5°C/41°F**
- Maximum room temperature: **32°C/89°F**
- The weighted sound pressure level of the machine is lower than 70dBA.

Espresso machine installation, linea mini

1) Fill water reservoir with potable water.

Once the espresso machine has been unpackaged, placed on a hard surface. Remove the drain tray and slide the water reservoir until the water reservoir fill cover is accessible. Remove the cover and fill water reservoir with potable water. Replace the fill cover and slide the water reservoir to the operating position and replace the drain tray. In order to connect the machine up to the water mains proceed according to the indications given in the Installation Guide and in compliance with any local/national safety standards of the location in which the machine is being installed.

To guarantee a correct and safe functioning of the machine and to maintain an adequate performance level and a high quality of the beverages being brewed it is important that the incoming water be of a hardness greater than 9°f (90ppm, 5°d) and less than 15°f (150ppm, 8.4°d), pH should be between 6.5 and 8.5 and the quantity of chlorides be less than 50mg/l. Respecting these values allows the machine to operate at maximum efficiency. If these parameters are not present, a specific filtration device should be installed, while always adhering to the local national standards in place regarding potable water.

2) Connect espresso machine to power supply.

Connect the espresso machine to a power supply that is rated in accordance with the serial plate on the espresso machine.

3) Filling the boilers with water.

Complete the following steps to properly fill the boiler tanks:

Steam boiler: Turn the main switch to position “1”, the steam boiler will then automatically fill to a predetermined level. When the correct water level in the steam boiler is reached, the machine will automatically stop filling.

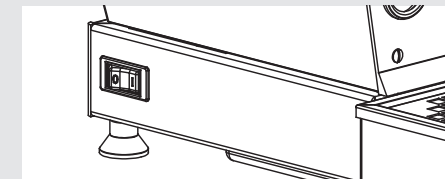

NOTE: It may be necessary to re-fill the water reservoir during this process.

Integrated brew group: The water flows inside the Integrated brew group directly when the water pump is activated. When the linea mini is turned on the electronics will activate the water pump to fill both boilers.

4) Verify filling of boilers.

The installation is now complete and the espresso machine should be heating to the operating temperatures.

Brewing after first installation

Once the first installation procedures are finished, before proceeding with brewing coffee, hot water and steam, please follow these steps:

- Engage the portafilter by inserting it into the group head and rotate the handle from left to right. Once the portafilter is inserted properly, you can move the paddle on the left side to start the flow of water through the portafilter. Brew water through the group for at least two minutes.
- Being careful to avoid burns, turn on each steam wand for at least one minute.
- Turn on the hot water valve for the time necessary to allow at least 1 liter of water to be brewed.

5) Waiting for the espresso machine to heat to operating temperature.

During this time, the pointer of the Integrated brew group pressure gauge may reach as high as 12 bar. This may happen anytime that the heating element is in the "on" condition. If the pressure exceeds 12 bar then it will be necessary to adjust the

expansion valve in such a manner that the pressure never exceeds 12 bar.

In normal operating conditions, the Integrated brew group pressure gauge can read anywhere from 0-12 bar. When brewing, the pressure should be set to approximately 9 bar.

The machine is ready to brew water when the power indicator light (red) is ON.

When the machine is warming up the power indicator light (red) is flashing.

NOTE: As the steam boiler reaches operating temperature you may hear air and steam escaping from the boiler. This is a normal sound. As the water boils, air in the boiler is replaced by steam and exits through the vacuum breaker. As the boiler get closer to operating temperature the vacuum breaker closes and the steam is no longer able to escape. This process allows the air in the steam boiler to escape and to be replaced by water vapor.

6) Machine plate:

Machine CE plate

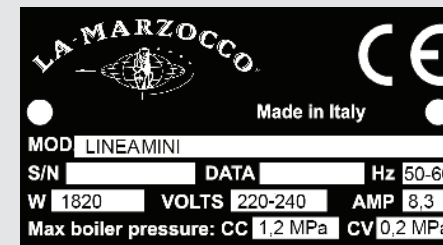

Machine ETL plate

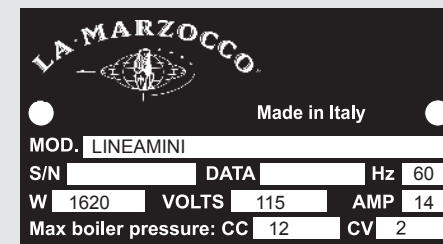

7) Adjusting the expansion valve.

The expansion valve is a component that limits the maximum pressure in the Integrated brew group. Heating the integrated brew group causes the water within to expand. Since the integrated brew group is completely saturated, the expanding water causes an increase in pressure within the boiler. Without a safety device the increase in pressure could cause a rupture in the boiler. The pressure in the integrated brew group should never exceed 12 bar. The valve is hot, so, using adequate protection, rotate the expansion valve clockwise to increase pressure. To decrease pressure, rotate the expansion valve counter clockwise (see the following diagram).

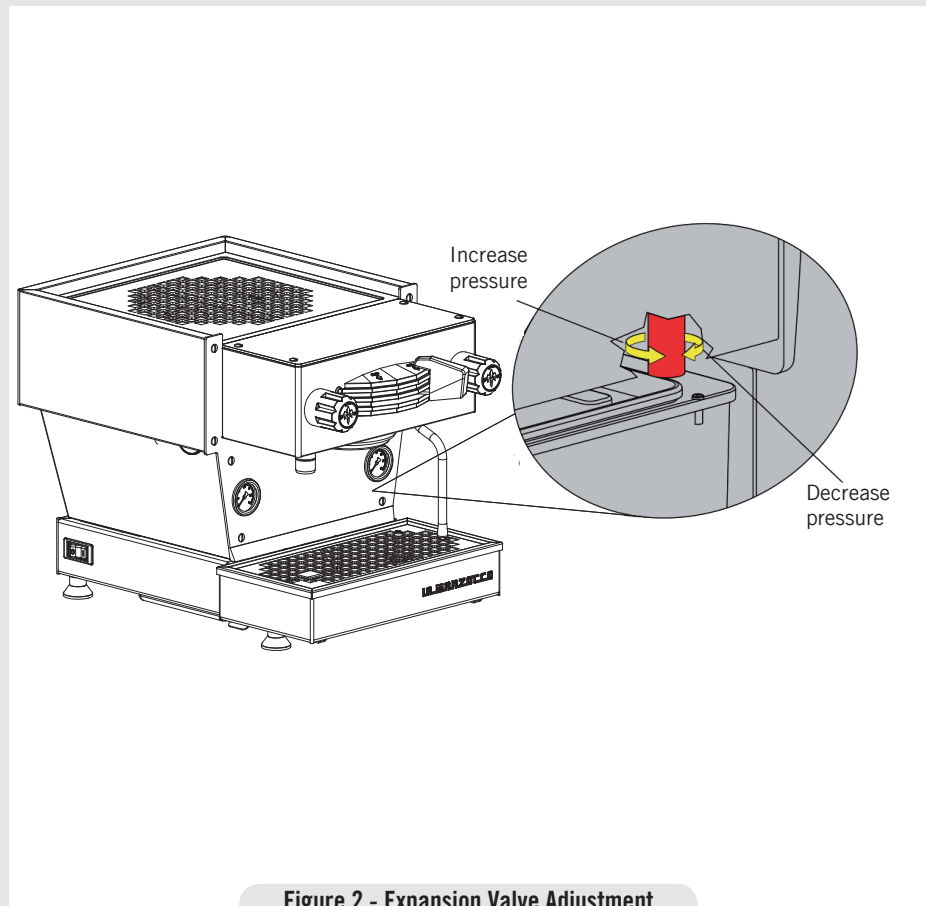

Figure 2 - Expansion Valve Adjustment

8) Adjusting water pump pressure.

The water pump is factory set at 9 bar pressure. If it becomes necessary to change the pressure please use the following procedure:

1. Remove the top tray and the lower tray.
2. Locate the water pump adjustment screw and loosen the lock nut.

3. Adjust the water pump pressure to the desired measurement.
4. Rotate clockwise to increase pressure and counter-clockwise to reduce pressure.

NOTE: The water pump pressure should be adjusted when the machine is operating and coffee is present in the portafilter.

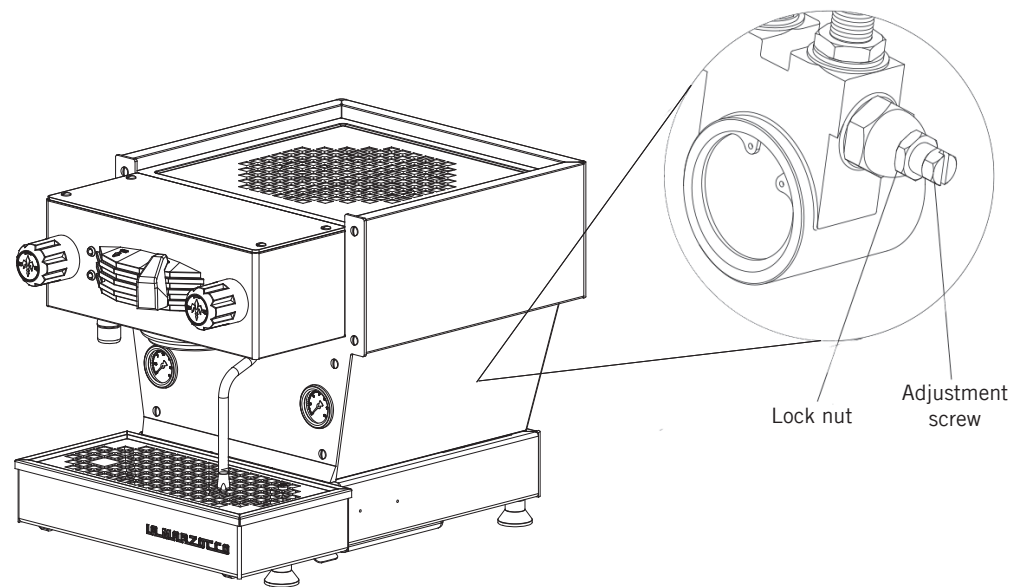

Figure 3 - Water Pump Pressure Adjustment

5. Operation

WARNING

The integrated brew group and steam boiler contain water at elevated temperature. Water temperature over 125°F / 52°C can cause severe burns instantly or death from scalding (integrated brew group 200°F/93.3°C - steam boiler 260°F / 127°C).

WARNING

The machine must not be dipped in, nor splashed with, water in order to clean it. For cleaning operations, please follow the instructions listed below very carefully.

WARNING

This machine is designed only for preparing coffee and hot drinks.

1. Installing the portafilter.

Install the portafilter by inserting it into the group head and rotate the handle from left to right. Once the portafilter is inserted properly, you can move the paddle handle from right to left to start the flow of water through the portafilter. It is important that the portafilter is at operating temperature prior to filling with coffee.

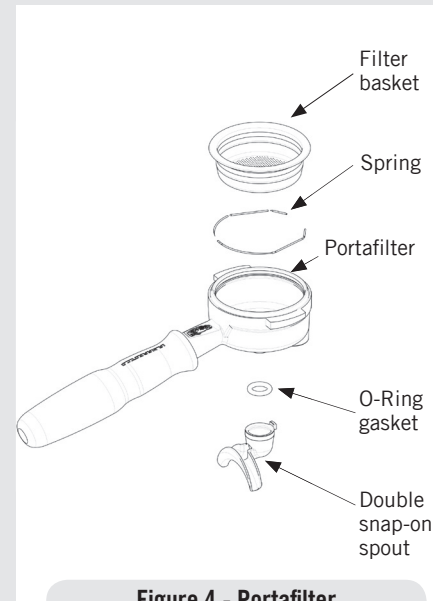

Figure 4 - Portafilter

Allow hot water to pass through the empty portafilter for a few seconds before the brewing process to pre-heat the portafilter.

NOTE: It is important to leave the portafilter locked in the espresso machine when not in use. The portafilter must remain heated for the brewing process to function correctly.

2. Brewing coffee. It is now possible to remove the portafilter to make a coffee beverage. Place some ground coffee in the portafilter basket using the single or double basket. Press down on the ground coffee with the supplied tamper and install the portafilter on the linea mini. Move the paddle handle from right to left to begin brewing (see Fig.1 page 8).

NOTE: Some users believe it is important to allow water to pass through the group head prior to installing the portafilter to flush any remaining coffee oils and particles from the group head. Some also flush just after brewing for the same reason. Please experiment to make the best possible procedure for your coffee. There are many techniques for brewing espresso. You can find instructions for many techniques on websites, blogs and forums. Some are

even monitored by professional baristas around the world.

3. Dispensing steam.

In order to allow for any condensed water in the wand to be released ALWAYS allow some steam to be discharged by turning on the valve before inserting the steam wand into the pitcher of liquid to be heated. Dip the steam wand into the liquid to be heated. Rotate the steam knob to activate the steaming process.

The steam valve has a variable flow control. The steam valve will lock in the fully on position only.

The steam will transfer heat to the liquid raising its temperature. Be careful not to allow liquid to overflow in order to avoid severe burns.

Steaming milk for cappuccinos and other beverages is very easy but making it just right requires some skill. Please experiment with various techniques to find the best method for your milk. You can find many discussions about the steaming of milk on the internet.

NOTE: It is important to have a sufficient volume of liquid in the steaming pitcher. Therefore if you intend to steam small amounts of milk it is necessary to use a small pitcher. If you intend to steam larger quantities of milk then it is necessary to use a larger steaming pitcher.

Using too little milk in a steaming pitcher can allow the milk to be “blown out” of the pitcher. A good rule to follow is to fill the steaming pitcher only half full of liquid.

NOTE: In order to prevent the heated liquid from being sucked back into the steam boiler it is recommended that you purge the steam system after heating any liquid. Purge the system by opening the steam valve for a few seconds to allow steam to escape to the atmosphere from the end of the steam wand.

4. Dispensing hot water.

You may dispense hot water by using the hot water nozzle. To dispense hot water rotate the left knob (see Fig.1 page 8).

This knob commands the hot water delivery.

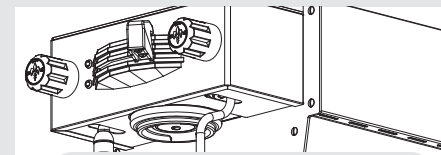

Figure 5 - Hot Water Knob

6. Key Features

WARNING
If the above-mentioned instructions are not adhered to the manufacturer cannot be held responsible for damage to persons or things.

1. Hot water dispensing.

Hot water may be dispensed from the Hot Water Wand on the left side side of the machine. This is accomplished by rotating the left knob (see Fig.1 page 8).

2. General notes for coffee preparation.

The portafilters must remain heated since they are at the lowest position of the group itself, and they are partially isolated from the group due to the rubber gasket between them. This can be accomplished by leaving the portafilters installed in the machine when not in use. The portafilter may also be actively heated by rotating group activation paddle to flush hot water through the portafilter then turning off the water flow.

3. Coffee grind.

The size of the coffee granules is extremely important in preparing a good cup of

coffee, along with the type of coffee blend used. The ideal grind can be determined by making various coffees using the amount of ground coffee that you would normally use for each cup (we recommend at least 6g). The best grind is that which allows coffee to flow out from the portafilter spouts neither too slowly, drop by drop, nor too quickly. A general rule is that a double dose should dispense approximately 60ml/ 2 fluid oz. of espresso in approximately 25 seconds. This time may be adjusted by varying the coarseness of the grind.

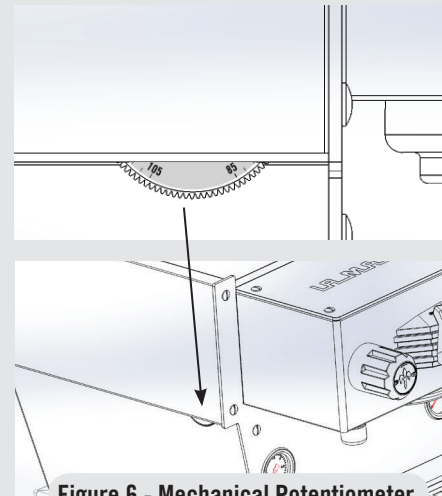

Figure 6 - Mechanical Potentiometer

N.B.

If the machine has not been used for more than 8 hours or, in any case, after long periods of being idle, in order to use the machine to its full potential it is necessary to perform some cleaning cycles before brewing beverages as follows:

- Groups: with the portafilters engaged in the groups brew water through each for at least two minutes
- Being careful to avoid burns, turn on the steam wand for at least one minute.
- Turn on the hot water valve for the time necessary to allow 1 liter of water to be brewed.
- If using the machine with water reservoir, change the water in the reservoir daily.

If the machine is not going to be used for long periods of time, it is advisable to follow these safety indications:

- Disconnect the machine from the water mains or interrupt the water connection via a mains tap.
- Disconnect the machine from the electrical mains.

7. Preventative Maintenance and Cleaning

WARNING
Jets of water should not be used to clean the machine, nor should it be placed where water jets are used.

WARNING
Do not remove the filter holder while relative group is brewing hot liquids. The integrated brew group contains water at elevated temperature. Water temperature over 125°F / 52°C can cause severe burns instantly or death from scalding.

WARNING
The machine must not be dipped in, nor splashed with water in order to clean it. For cleaning operations, please follow the instructions very carefully.

WARNING
The expansion valve can discharge water as hot as 200°F / 93°C. Adequate protection for handling this component is needed before attempting to adjust.

WARNING
This machine is designed only for preparing coffee and hot drinks.

Cleaning (Daily)

1. Cleaning the diffuser screen.

During the discharge operation (subsequent to coffee brewing), small amounts of coffee grounds may slowly build-up on and obstruct, even partially, the diffuser screen. Turn off the machine and remove the diffuser screen by unscrewing the diffuser screw. Soak in detergent powder liquid following the instructions of detergent manufacturer. Rinse thoroughly with clean water. Install and run hot water through the group head several times with the screen installed.

2. Cleaning the brewing system.

Insert the blind filter into to the portafilter and put the correct amount of espresso cleaning product (following the product's instructions) into the filter, engage the portafilter into the group you want to clean.

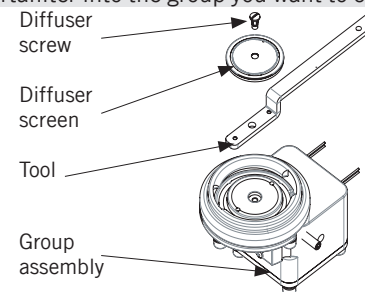

Figure 7 - Integrated Brew Group

- Move the group activation paddle for said group, as if you were making a regular cup of coffee. Stop the water after about 15-20 seconds.
- Start and stop the group several times until you notice clear water being released instead of soapy water when you remove the portafilter. Do not remove the portafilter when group is dispensing water.
- Rinse the group using a normal filter in the portafilter, by running hot water through it several times.

3. Cleaning the body.

Wipe the stainless steel surfaces with a soft, non abrasive cloth in the direction of the glazing marks, if any. Do not use any alcohol or solvents whatsoever on painted, imprinted, or plastic parts in order not to damage them. Clean the side panels using a soft cloth. Clean only with a damp soft cloth.

4. Cleaning the hot water and steam nozzles.

Steam nozzles must be cleaned immediately after use with a damp cloth and by producing a short burst of steam so as to prevent the formation of deposits inside the nozzles themselves, which may alter the flavor of other drinks to be heated. Hot water nozzles must be cleaned periodically with a damp cloth. If milk residue is present on the steam wand, soak the tip in a container of hot water, then it will be possible to wipe the tip clean. Repeat process if residue remains.

NOTE: This cleaning schedule is based upon a moderate to average use (20-300) cups per day. If machine use is less than moderate then this schedule may be adjusted accordingly.

Cleaning (Periodic)

1. Draining boilers: Both the Integrated brew group and the steam boiler may be drained and refilled to reduce the chance of mineral deposits build up on the inside walls of the inside surfaces. Additionally this draining process can be used to remove water that has a bad odor or taste.

Drain the steam boiler: Turn OFF the machine. Remove the rear panel assembly. Locate the ball valve on the bottom right side of the machine. Hold the ball valve with one tool and remove the brass cap on the end of the valve. Move the espresso machine close to a waste drain and tip machine at an angle to point the valve into the waste drain.

Drain the Integrated brew group: Turn OFF the machine. Using adequate protection or an appropriate tool, loosen the expansion valve until water begins to flow freely. Then open the ball valve on the left side.

2. Clean the water reservoir: The water reservoir needs to be cleaned periodically to ensure that no algae forms on the inside surfaces. To clean, first remove the water reservoir from the machine. Disconnect the clear plastic water intake hose. Unscrew all screws from the cover to separate the parts. Wash all parts with warm soapy water. All parts are dishwasher safe.

8. Installation Guide

- | | | | |
|-------------------------------------------|---------|-------------------------------------|---------|
| 1. Unpack linea mini Espresso Machine | page 19 | 7. Adjust the expansion valve | page 23 |
| 2. Fill with water (initial fill) | page 19 | 8. Monitor steam boiler pressure | page 24 |
| 3. Drain box alignment | page 20 | 9. Brew espresso | page 25 |
| 4. Connect to power supply | page 20 | 10. Verify working boiler pressures | page 25 |
| 5. Turn on main power | page 21 | 11. Coffee boiler temperature | page 26 |
| 6. Monitor integrated brew group pressure | page 22 | 12. Steam boiler temperature | page 26 |

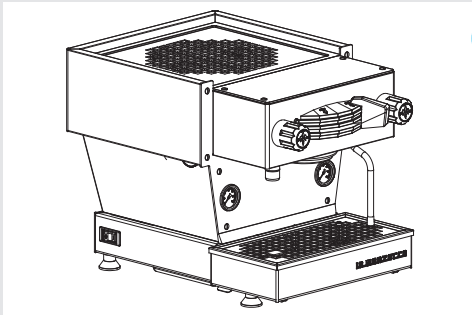

1

Unpack espresso machine and set on a level surface. Ensure all accessories are included with shipment. Check for any visible damage to espresso machine.

WARNING
The coffee machine must be placed in a horizontal position on a counter higher than 90 cm from the ground.

2

Remove/Open the fill cover and fill the reservoir with filtered water. Slide the reservoir back into position and replace the drain box. Make sure the drain box is inserted fully. The water reservoir must make contact with the level indicators on the rear side.

NOTE: The linea mini is configured to work with the water reservoir.

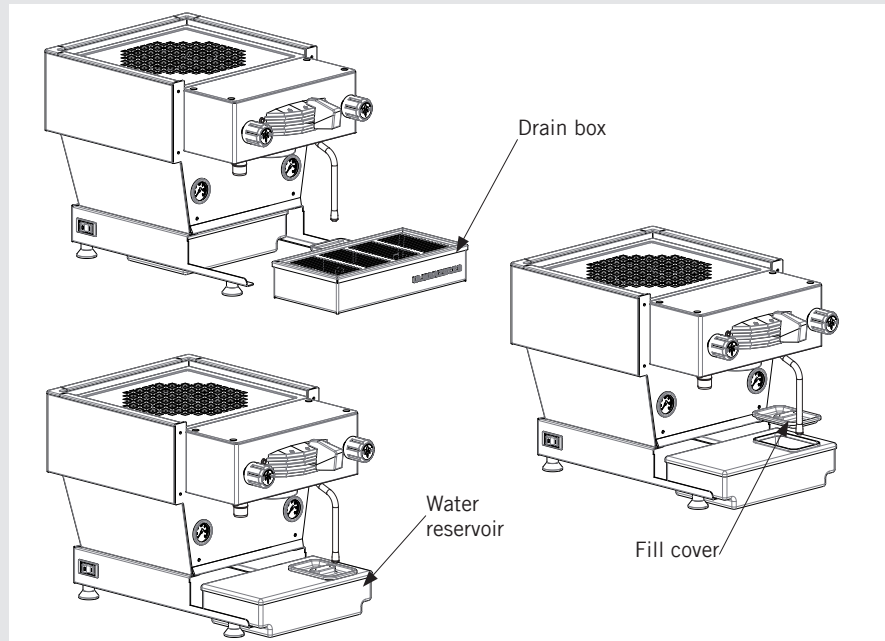

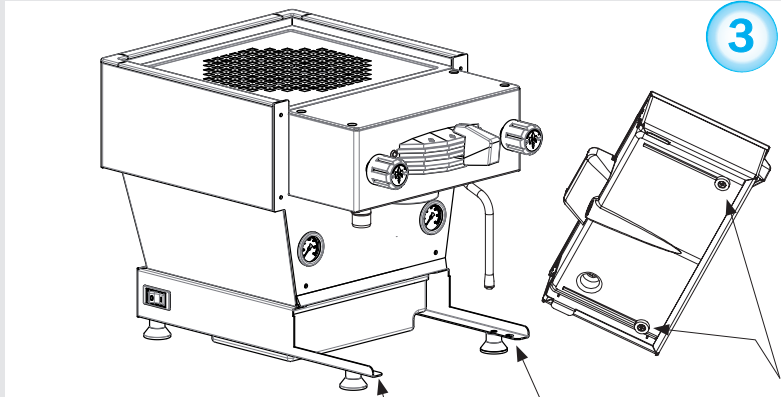

3

IMPORTANT NOTE:

The drain box must be installed correctly for the machine to function properly. The drain box has two magnets that mate with two alignment grooves on the base of the Linea Mini. When installing the drain box, ensure that the alignment magnets are inserted into the alignment grooves. It may be necessary to push slightly on the front of the drain box to achieve proper alignment. When the machine is ON and the water tank is full, the water reservoir indicator light (blue) is ON; if the water tank is empty the water reservoir indicator light (blue) is flashing.

Alignment magnets and grooves

Alignment grooves

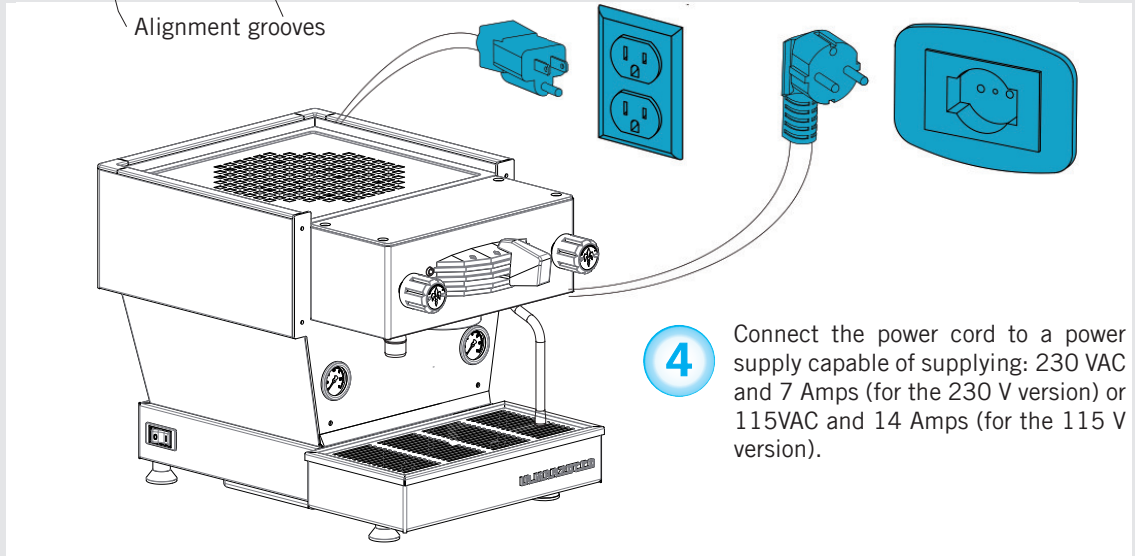

4

Connect the power cord to a power supply capable of supplying: 230 VAC and 7 Amps (for the 230 V version) or 115VAC and 14 Amps (for the 115 V version).

WARNING

The manufacturer declines any responsibility for any event leading to liability suits whenever grounding has not been completed according to current local, national, and international regulations and electrical codes, or if other electrical parts have been connected improperly.

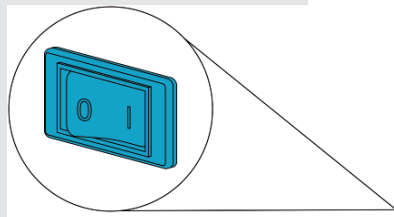

- 5 Turn on power by pressing the main power switch. The main power switch may be found on the left rear of the machine.

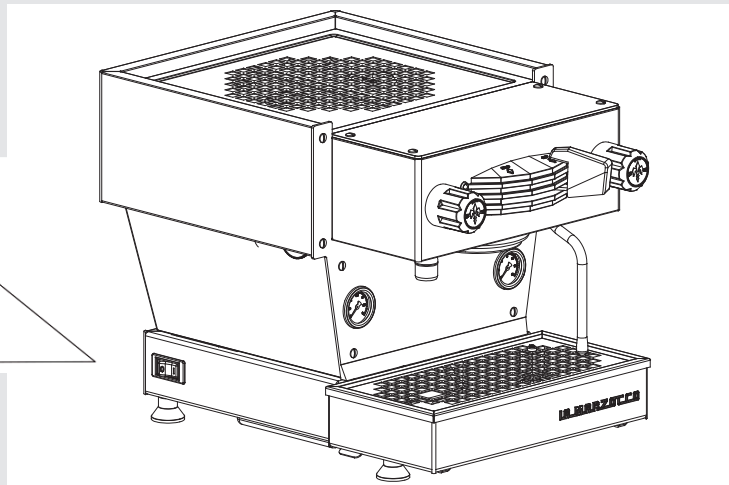

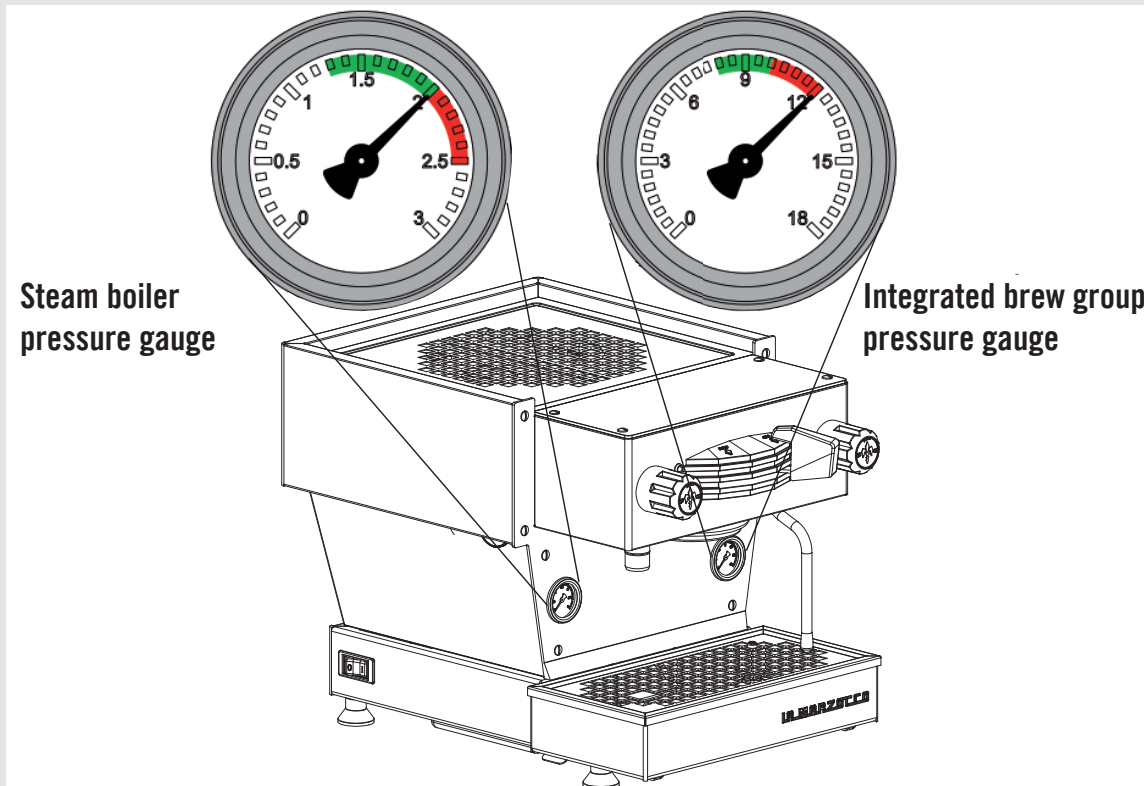

6

Next it will be necessary to check the expansion valve. As the integrated brew group heats to operating temperature the pressure in the integrated brew group will rise. There is an expansion valve behind the drain tray that allows some water to escape during this process to limit the maximum pressure in the integrated brew group to 12 bar. Please monitor the integrated brew group pressure gauge during the initial heating process. You should notice the gauge approach 12 bar and stop. If the pressure gauge does not reach 12 bar or if the pressure gauge rises above 12 bar, then it will be necessary to adjust the expansion valve. Please follow the next step to properly adjust the expansion valve.

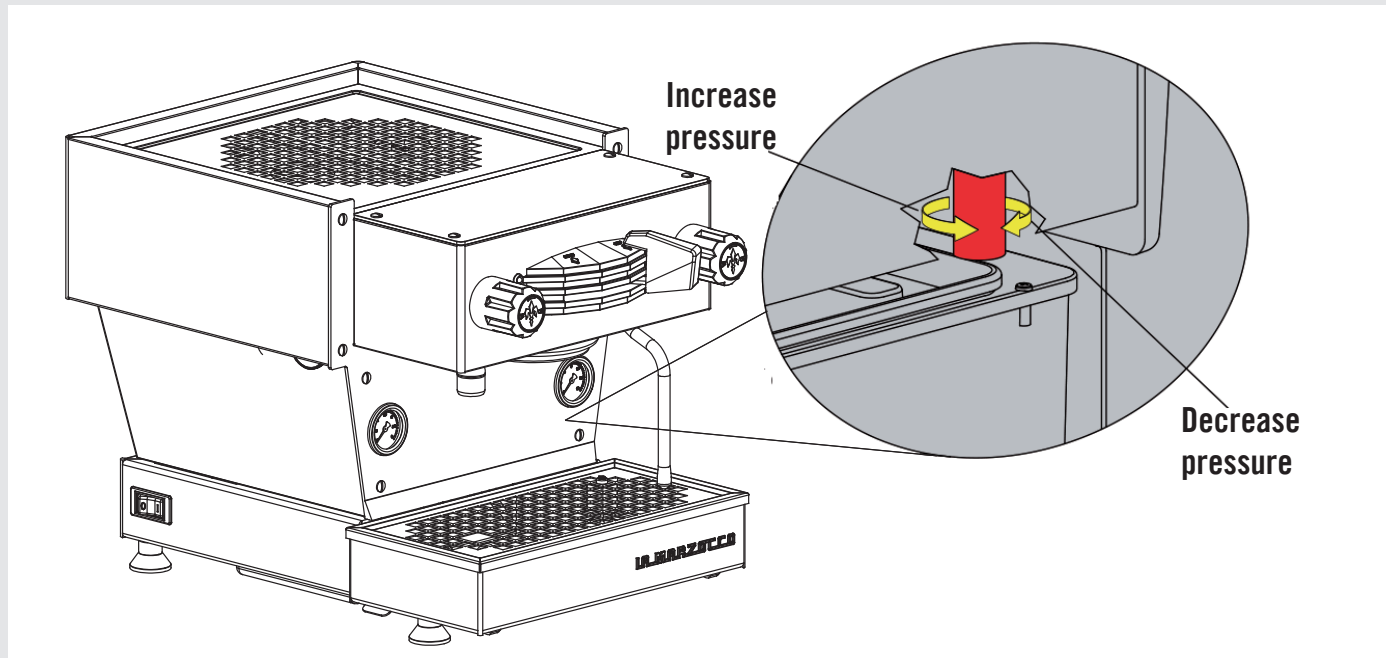

- 7** Please follow this procedure if it is necessary to adjust the expansion valve. First remove the drain box to access the expansion valve. The expansion valve protrudes through the sheet metal, has the shape of a hexagon, is brass in color and 18 mm (tool). The valve will be hot, so, using adequate protection, in order to adjust the expansion valve rotate the valve clockwise to raise the pressure and counter-clockwise to reduce the pressure. It may be necessary to use a spanner to rotate the expansion valve in 1/4 turn or less increments until the desired pressure is achieved. Replace the drain box after each adjustment to ensure the machine is operating correctly.

WARNING
The expansion valve can discharge water as hot as 200°F / 93°C. Adequate protection for handling this component is needed before attempting to adjust.

8

You may also monitor the steam boiler heating progress by watching the steam boiler pressure gauge. The steam boiler is set at approximately 2.0 Bar of pressure at the factory. Once the pressure gage reaches this point the heating will stop.

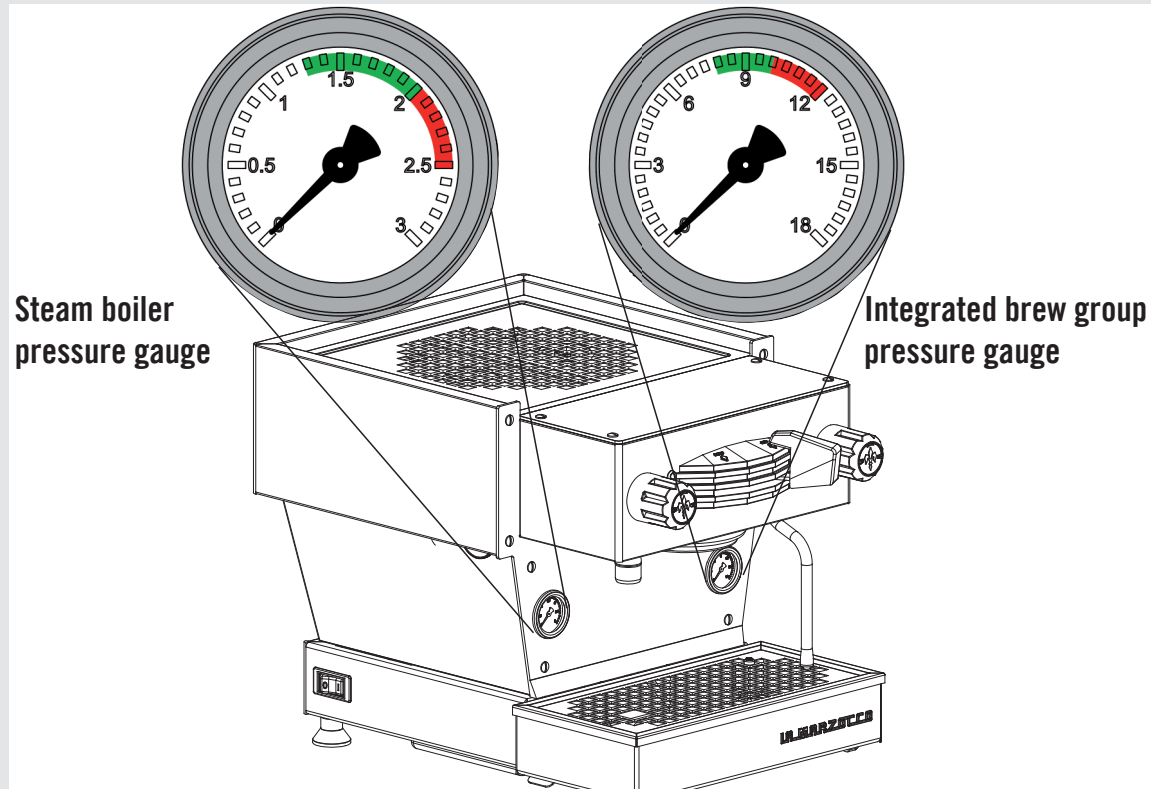

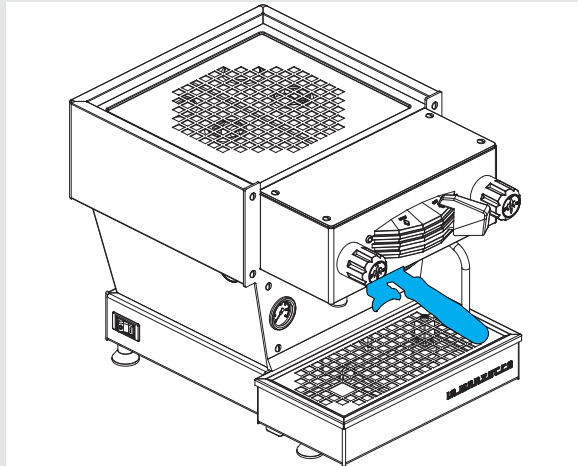

9

When the espresso machine is ready, (red indicator light ON) place ground coffee into the portafilter and activate the brewing process.

10

When brewing, the integrated brew group pressure should be between 8-10 bar. The steam boiler pressure should be set at 2 bar but can operate at any setting between 1.3 bar and 2 bar.

Steam boiler
pressure gauge

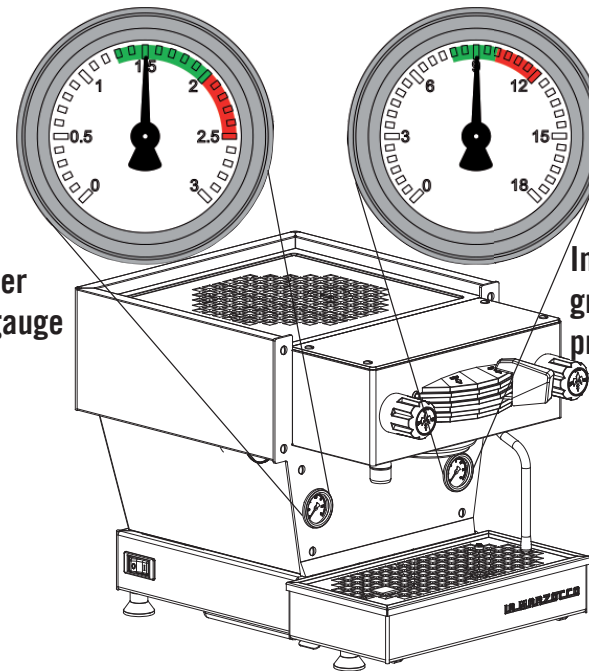

Integrated brew
group
pressure gauge

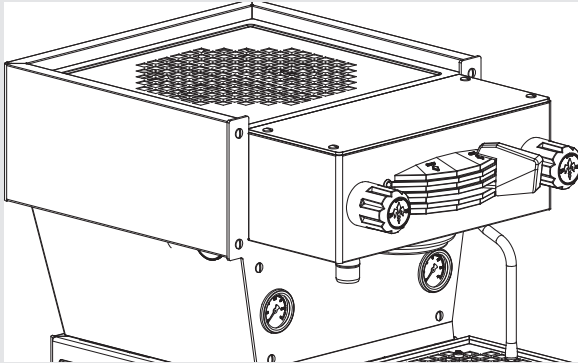

11

This parameter is set at the factory at a preset nominal temperature. The temperature of the brewing water is measured at the most critical point in the integrated brew group where temperature fluctuation is the greatest.

The temperature of the water exiting the group head is held constant by means of the mass of the group casting. Even though the temperature of the water may vary slightly, the temperature of the water exiting the group is constant.

To properly calibrate the temperature of any espresso machine it is important to measure the temperature of the water exiting the group by means of an external temperature measuring device.

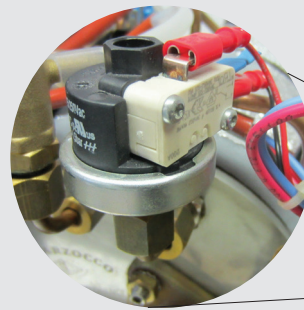

12

It is possible to regulate the pressure of the steam boiler by pressure switch.

