

Pre-Installation Specifications Modbar AV 2 Group + Steam

Instructions for plumber, electrician, architect or designer, outlining the specific requirements **PRIOR TO INSTALLATION** of the Modbar AV Espresso System.

Prepare your site for the installation of three to four taps in the countertop surface, three to four drip trays, and two modules on well-ventilated shelves or rack directly below the taps.

Designer or Architect Specifications — Above Counter

- A dry, well-ventilated counter area, which is between 813mm and 965mm high, with a depth of at least 508mm.
- An area to be provided near the machines for a grinder and working area. To maintain a clean look, we recommend considering grinder placement and location. Building a drop into the countertop between 100mm and 200mm can be effective.
- 38mm holes drilled through the countertop for each tap and appropriate holes cut for each drip tray. Cuts should be made prior to the installation using the Modbar AV layout template.
- If installing multiple taps, leave 30mm between center holes on adjacent taps.
- If installing scales, countertop surface thickness must be between 19mm and 100mm.

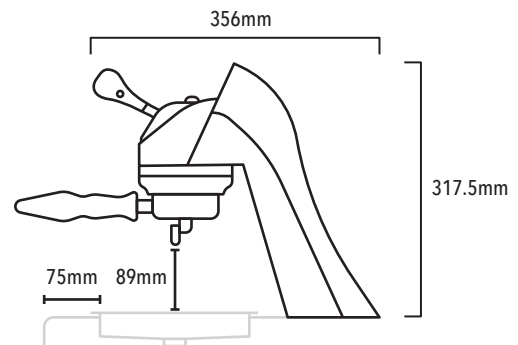
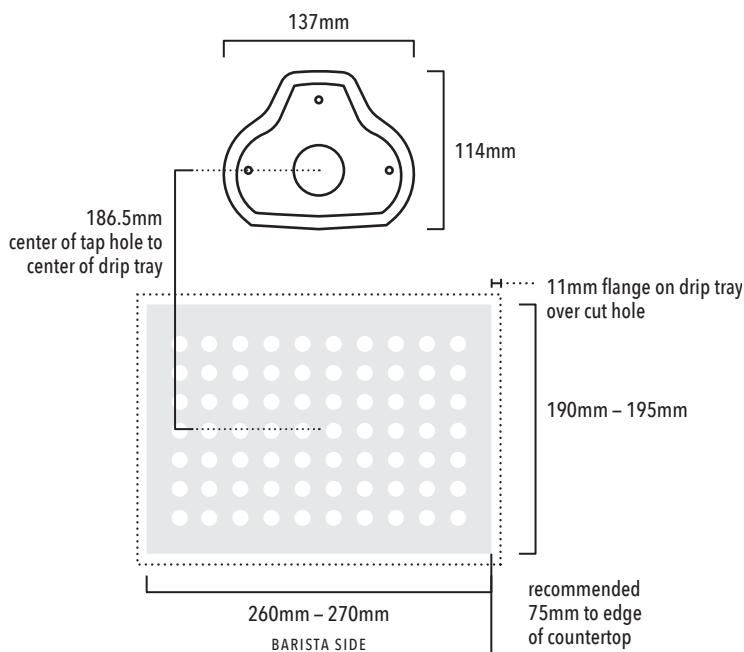

Designer or Architect Specifications — Below Counter

- Cabinet space should have a depth of at least 508mm and a width of at least 660mm to allow for clearance around and behind the modules.
- Shelves or a wire rack should be provided to support each module.
- Allow a 30mm by 30mm area within 1.5 meter of the module for external pump. (Included)
- We do not recommend installing cabinet doors in this space.
- Cafe owner should consider where filtration will go. Water filtration is required for all coffee equipment.

Water Specifications

Your filtration system should produce water with the following properties:

T.D.S.	90–150ppm
TOTAL HARDNESS	70–100 ppm
TOTAL IRON	0–0.02ppm
FREE CHLORINE	0–0.05ppm
TOTAL CHLORINE	0–0.1ppm
PH	6.5–8

ALKALINITY	40–80ppm
CHLORIDE	0–30ppm
LINE PRESSURE	35–70 PSI
FLOW RATE	2 GPM/8 LPM

Module Dimensions & Specifications

MODULE	WIDTH (+CLEARANCE)	DEPTH (+CLEARANCE)	HEIGHT (+CLEARANCE)	WEIGHT	VOLTAGE	RECEPTACLE	WATTAGE
Espresso AV	432mm (+280mm)	381" (+75")	216mm (+150mm, or 200mm if installing scales)	18.1 kg	208-240V	NEMA 6-20R	3200
Steam	432mm (+280mm)	381" (+75")	216mm (+75mm, 150mm or 200mm)	18.1 kg	208-240V	NEMA 6-20R	3600

Required Module Clearance

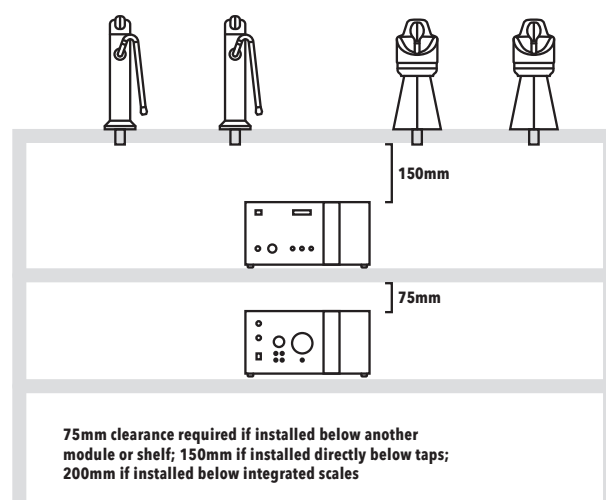
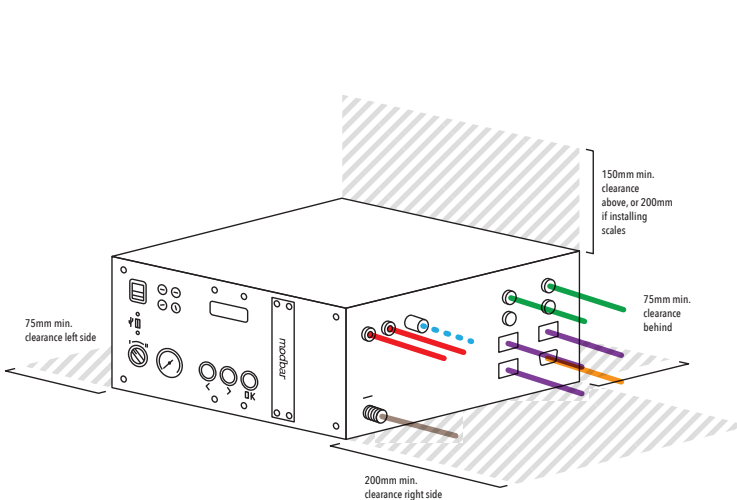

Plumber Specifications

- Each module requires a 9.5mm angle stop valve, with a flow rate of at least 7.6 liters per minute.
- Pressure between 35 and 70 PSI. If pressure is too high i.e. >70psi, pressure regulator is required.
- Owner should communicate with equipment installer about water filtration requirements. Talk with your sales representative for more information.

Waste Outlet

- Drain connection is male 19mm barb connection. Required 19mm armored drain hose (1.5 meter) is included with your system.
- Open gravity drain of minimum 38mm interior diameter within 1.22 meter of module(s).
- Drain must be located lower than the bottom-most module in your Modbar system. There must be no less than 830mm per meter downward slope in drain line.

Electrician Specifications

- The electrical requirements are 208-240 Volt single-phase, 50-60hz supply with 20 amp per module. (Subpanels are useful in multiple-module installations.)
- All modules will be supplied with a NEMA 6-20P plug end on the power cord. Each module is provided with a 6 foot power cord exiting machine from the right-hand side. Location of electrical supply should take this into account. Receptacle should be no further than 1.5 meter from the modules, with the electrician responsible for installation of NEMA 6-20R.

